



# GUS™ VERTICAL AXIS WIND TURBINES INSTRUCTION AND OPERATION MANUAL





# GUS™ VERTICAL AXIS WIND TURBINES INSTRUCTION AND OPERATION MANUAL





# GUS™ VERTICAL AXIS WIND TURBINES INSTRUCTION AND OPERATION MANUAL

## WELCOME!

Thank you for your purchase of a GUS™ (Green Utility System) Vertical Axis Wind Turbine (VAWT), a renewable energy electrical generator that uses the wind as a power source!

GUS™ Wind Turbines are durable and have a long life span, thanks to their design and construction.

GUS™ Wind Turbines start producing energy at low wind speeds (4.5mph) and take advantage of the gentlest winds. The double helix blade configuration efficiently captures wind power from any direction. This feature is particularly useful in shifting wind directions, gusting or varying wind velocities.

## INSPECTION

Initial inspection should include a familiarization with the normal appearance of the wind generator. Take a few moments for a close-up look at the wind generator and turbine blade assembly.

Make sure:

1. There is no evidence of damage from shipping (paint scratches, material cracks, bent stays or shaft etc.).
2. There are no missing fasteners, all fasteners are tight, and joints are even and sealed.

## WARNING!

**THERE ARE NO OWNER SERVICEABLE PARTS INSIDE THE GENERATOR. ATTEMPTING TO OPEN THE GENERATOR HOUSING WILL INVALIDATE THE WARRANTY AND COULD BE DANGEROUS.**



# GUS™ VERTICAL AXIS WIND TURBINES INSTRUCTION AND OPERATION MANUAL

## INDEX

<b>1.0. SAFETY PRECAUTIONS .....</b>	<b>6</b>
<b>2.0. SITE SELECTION FOR TURBINE.....</b>	<b>6</b>
<b>3.0 MECHANICAL INSTALLATION OF TURBINE.....</b>	<b>7</b>

**All GUS™ Wind Turbines are equipped with anchor bolts that extend below the bottom plate of the generator. The user must supply flange or plate and structure assembly for mounting. \*Refer to detail drawing (Attachment A).**

<b>3.1 Pole Mount</b>	<b>7</b>
<b>3.2 Roof Mount</b>	<b>7</b>
<b>3.3 Side Mounting to a Structure:</b>	<b>7</b>
<b>4.0 ELECTRICAL INSTALLATION OF TURBINE GENERATOR.....</b>	<b>8</b>
<b>4.1 Requirements for electrical system</b>	<b>8</b>
<b>4.2 Lightning Protection.</b>	<b>8</b>
<b>4.3 Wiring</b>	<b>8</b>
<b>4.4 Recommended Disconnect / Brake</b>	<b>9</b>
<b>4.5 Wiring to a Battery Charge Controller</b>	<b>9</b>
<b>4.6 Generator Configuration</b>	<b>9</b>
<b>4.6.1 Standard Configuration</b>	<b>10</b>
<b>4.6.2 Star or Wye Configuration</b>	<b>11</b>
<b>4.6.3 Delta</b>	<b>11</b>

The manufacturer reserves all rights to modifications without further notice.



# GUS™ VERTICAL AXIS WIND TURBINES INSTRUCTION AND OPERATION MANUAL

<b>4.6.4 Difference between Star and Delta</b>	<b>12</b>
<b>5.0. TURBINE OPERATION</b>	<b>12</b>
<b>5.1 Initial Operation/ Emergency Shut Off Switch</b>	<b>12</b>
<b>5.2 Normal Operation</b>	<b>13</b>
<b>5.3 Maintenance</b>	<b>13</b>
<b>5.4 Service</b>	<b>14</b>
<b>5.4.1 Electrical System Service</b>	<b>14</b>
<b>ATTACHMENT A: GUS™ 1EL DRAWING</b>	<b>15</b>
<b>ATTACHMENT B: BASIC TURBINE BATTERY CONNECTION</b>	<b>16</b>
<b>ATTACHMENT C: SPUN CONCRETE POLE</b>	<b>17</b>



# GUS™ VERTICAL AXIS WIND TURBINES INSTRUCTION AND OPERATION MANUAL

## 1.0. SAFETY PRECAUTIONS

GENERATOR SYSTEMS SHOULD BE CONNECTED AND MAINTAINED BY QUALIFIED ELECTRICAL PERSONNEL.

THE ENDS OF THE WIRES COMING FROM THE GENERATOR MUST NEVER BE LEFT UNCOVERED: THE ELECTRICITY PRODUCED BY THE GENERATOR MAY BE HIGHLY DANGEROUS EVEN DURING PARTIAL ROTATION OF THE BLADE CONFIGURATION.

INSTALLATION OR SERVICE OF THE TURBINE MUST NOT BE DONE IN WINDY WEATHER.

INJURY CAN RESULT WHEN CONTACT IS MADE WITH ROTATING TURBINE BLADES. ENSURE ADEQUATE SUPERVISION FOR ANY PERSON, PARTICULARLY CHILDREN WHEN CLOSE ACCESS IS POSSIBLE.

APPROPRIATE SAFETY HARNESS AND RESTRAINTS ARE STRONGLY RECOMMENDED WHEN WORKING AT HEIGHTS OR ON ROOFTOPS.

## 2.0. SITE SELECTION FOR TURBINE

Considerations for Site Selection:

Place your turbine in a location to access as much wind as practical for your wind generator. In general, wind speed increases with height above the ground; to capture the most wind, mount the unit on a pole or structure. Select an open area with few obstructions to slow the wind (trees, buildings, fences, etc.). Consider the prevailing wind direction and locate the turbine with direct exposure to the dominant winds.

Wiring is required to bring the electrical power from the generator to your batteries or other system components. Consider the distance and physical access required for the components of your system. Don't forget to investigate buried hazards and utilities before you start to dig if you are installing a new pole or buried wiring.



# GUS™ VERTICAL AXIS WIND TURBINES

## INSTRUCTION AND OPERATION MANUAL

### 3.0 MECHANICAL INSTALLATION OF TURBINE

All GUS™ Wind Turbines are equipped with anchor bolts that extend below the bottom plate of the generator. The user must supply flange or plate and structure assembly for mounting. \*Refer to detail drawing (Attachment A).

Considerations for Installation:

- Use experienced trained personnel for securing a safe permanent mount
- Choose an installation time of minimal wind if hoisting or working at height
- Confirm matching pattern and hole size for your anchor assembly before time of installation.

#### 3.1 Pole Mount

Direct Burial Concrete Poles are used for many turbine installations; refer to Attachment C: Spun Concrete Pole. They offer a variety of advantages including pre-formed wire way and maintenance-free long life. Wood, fibreglass and metallic poles are also available (preferably without need for guy wires).

#### 3.2 Roof Mount

Consult a licensed engineer or architect to design the attachment for your building.

#### 3.3 Side Mounting to a Structure:

Ensure adequate clearance for reasonable airflow and blade rotation.



# GUS™ VERTICAL AXIS WIND TURBINES

## INSTRUCTION AND OPERATION MANUAL

### 4.0 ELECTRICAL INSTALLATION OF TURBINE GENERATOR

#### **WARNING!**

DURING ALL THE CONNECTING WORK THE ROTATION OF THE GENERATOR MUST BE STOPPED, BECAUSE THE VOLTAGE PRODUCED BY THE GENERATOR IS HIGHLY DANGEROUS.

#### **WARNING!**

WIRING A GENERATOR SYSTEM REQUIRES A REMINDER FOR THE ELECTRICAL INSTALLER BEFORE ATTEMPTING FINAL HOOK-UP. THE POWER PRODUCED BY THE GENERATOR FROM EVEN A PARTIAL ROTATION OF THE SHAFT WILL DO ONE OF TWO THINGS IF PROPER PROCEDURE IS NOT FOLLOWED. THE SHOCK FROM THE UNEXPECTED POWER WILL LEAD TO PERSONAL INJURY OR THE OTHER ELECTRICAL COMPONENTS CONNECTED WILL BE DAMAGED BEFORE THE WIRING IS COMPLETED.

#### 4.1 Requirements for electrical system

GUS™ wind turbines have been designed and manufactured to function stand-alone or grid connected. For installation electricity safety regulations must be met. Use a licensed electrician or certified technician for installing this equipment.

#### 4.2 Lightning Protection.

Lightning protection is especially important when the turbine is located higher than the surrounding structures or terrain. In order to protect the turbine against lightning, a copper cable (AWG 000) should be used to connect the metallic bolts (used to fasten the generator) and the mounting flange to an earth ground rod. Increased protection is also available for special cases by using lightning arrestors in addition to the earth ground.

#### 4.3 Wiring

Complete all connections before connecting the generator to avoid damage to components. When wiring a power generator to any other components, plan carefully and work safely.

Always consult your local electrical code.



# GUS™ VERTICAL AXIS WIND TURBINES INSTRUCTION AND OPERATION MANUAL

## 4.4 Recommended Disconnect / Brake

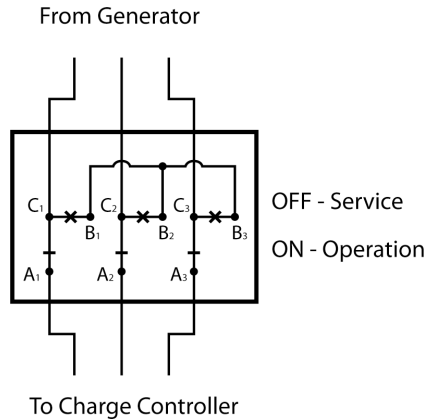

### 2-Position, 3 Pole Switch

#### **Requirements:**

*GUS™-1A, 1B, 1ES, 1EL* -30 AMP

*GUS™-5, 10, 15* -50 AMP

A 2-position switch can provide electric braking resistance for the generator shaft rotation when the windings are shorted together. In the short circuit position, the turbine rotation will noticeably slow in moderate winds and stop rotating completely in light winds. This switch is not a mandatory requirement, but an option strongly recommended.

## 4.5 Wiring to a Battery Charge Controller

The sequence of wiring is critical. The charge controller often requires an output load to prevent damage to the circuit board.

The non-arcing charge controller and the batteries should be placed in close proximity (less than 6 feet apart). The temperature of the space between the controller and batteries should be within the range of 35° F and 90° F steady and it must have good air circulation.

Refer to detailed instructions on your selected charge controller for complete wiring information.

## 4.6 Generator Configuration

### **WARNING!**

**DURING ALL THE FINAL CONNECTING WORK, THE ROTATION OF THE GENERATOR MUST BE STOPPED. VOLTAGE PRODUCED BY THE GENERATOR IS HIGHLY DANGEROUS.**



# GUS™ VERTICAL AXIS WIND TURBINES INSTRUCTION AND OPERATION MANUAL

## 4.6.1 Standard Configuration

The GUS™ Wind Turbine comes with a junction box terminal strip in Star Configuration as standard.

# GUS™ VERTICAL AXIS WIND TURBINES INSTRUCTION AND OPERATION MANUAL

## 4.6.2 Star or Wye Configuration

With star or Wye, the start of each of the three phases is connected together. Connections are taken from the start of the three windings to give the three leads. Factory installed jumper wires connect terminal 5-6 and 4-5 (accessible at the generator junction box).

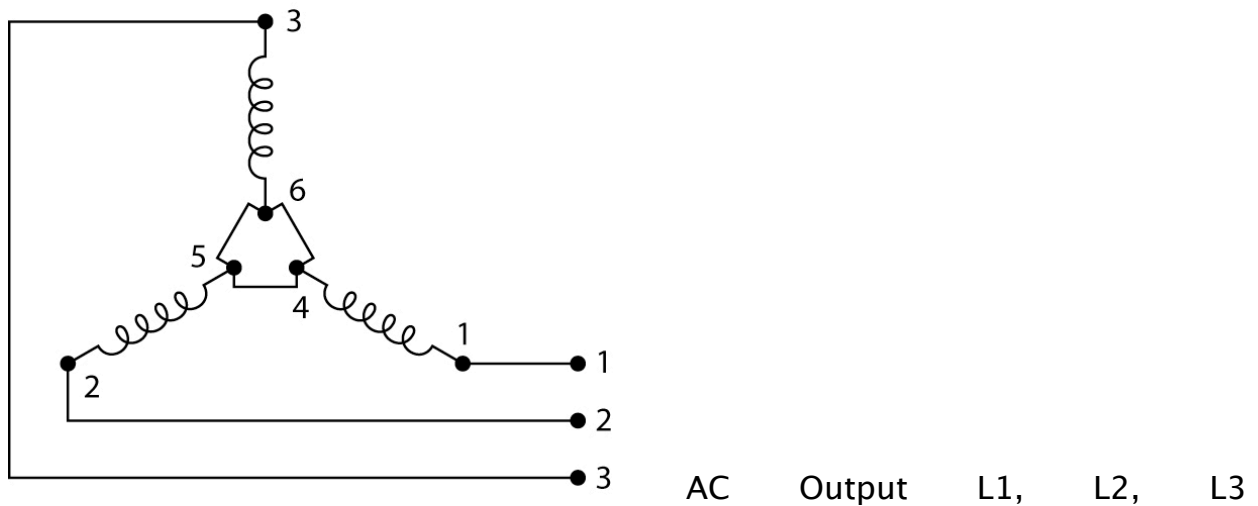

## 4.6.3 Delta

Delta configuration is possible by making the appropriate changes in the generator junction box.

With Delta the starts and ends of the phases are connected. The end of phase 1 is connected to the start of phase 2, the end of phase 2 to the start of phase 3, and the end of phase 3 to the start of phase 1. Connections are taken from the three start-end junctions to give the three phase output leads. Jumper wires should connect terminals 2-4, 1-6 and 3-5 in delta configuration.

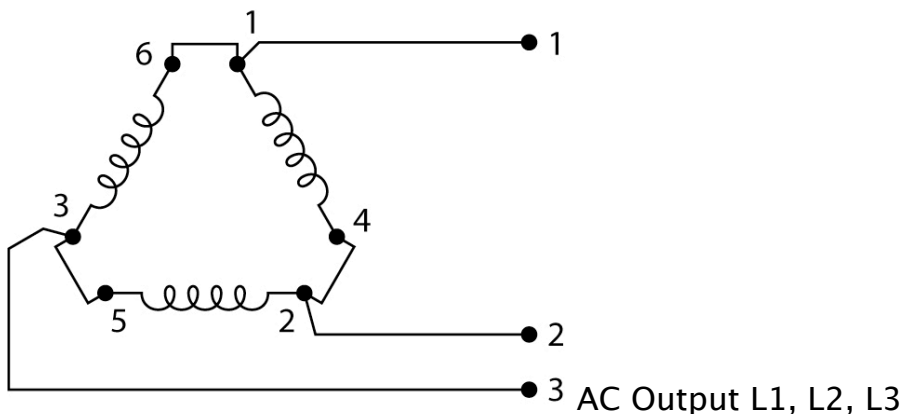

# GUS™ VERTICAL AXIS WIND TURBINES INSTRUCTION AND OPERATION MANUAL

## Star

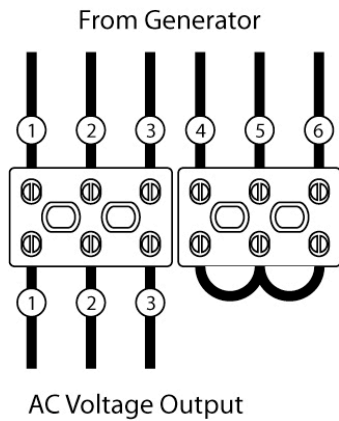

## Delta

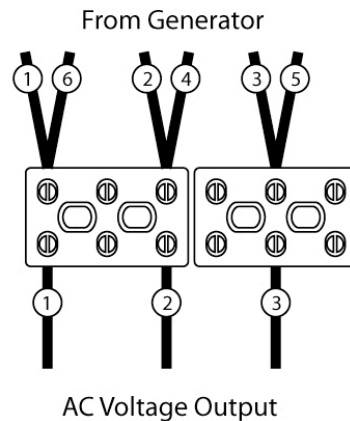

In either configuration, the three output wires can then be connected to a Rectifier or Charge Controller to convert the generated AC voltage into DC voltage for charging a battery bank.

### 4.6.4 Difference between Star and Delta

A simple explanation regarding the difference between star and delta is:

- Star generates a high voltage at a low current
- Delta generates a low voltage at a high current

The total (no load) power generated is the same.

Since star and delta wiring both give the same power, why does it matter which is used? A GUS™ wind turbine wired in Star will generate a higher voltage at lower RPM. A GUS™ wind turbine wired in Delta may require more effort (wind) to get it turning.

## 5.0. TURBINE OPERATION

### 5.1 Initial Operation/ Emergency Shut Off Switch.

Prior to operating the unit, familiarization should include:

- Review of electrical safety systems and local regulations
- Visual inspection of all installation supports and fasteners
- Confirmation of smooth, quiet rotation of the shaft assembly



# GUS™ VERTICAL AXIS WIND TURBINES

## INSTRUCTION AND OPERATION MANUAL

When the installation has been completed and you are ready to begin operating your wind generator release any temporary restraints to rotation. If you have installed a 2-position switch/ brake, move the switch to the operating position. The rotation of the shaft should be smooth and silent in even light winds.

### 5.2 Normal Operation

Familiarization with normal operation should include:

- Observation in a variety of wind conditions combined with varying electrical loads
- Note silent operation and relative speed of rotation

When rotating in normal winds the rotation speed of the shaft will be affected most by the velocity of the wind and the actual amount of power being produced. There are differences in speed of shaft rotation that result from electrical changes rather than wind gusts. As an example you will notice a difference in operation of 2 identical units if one turbine is keeping a back-up battery fully charged and the second is working to power an operating fixture.

Operational GUS™ wind turbines should be inspected regularly as dictated by site conditions.

Annual close visual inspection of fasteners and joints should confirm no requirement for maintenance activity; however, if loose fasteners or abnormality is observed, prompt remedial action could avoid a more serious problem. It is recommended to use thread locking adhesive in combination with any required fastener replacement.

The turbine blades should remain balanced and relatively clean. Any excessive build-up of dirt or foreign material may lead to imbalance and unsatisfactory operation.

### 5.3 Maintenance

GUS™ wind turbines are equipped with high quality bearings designed for a long service life within the expected design conditions. Do not allow penetration of the generator housing for any reason. Where external grease fittings are provided; addition of the recommended lubricant (GUS™ Grease) in minimum amounts every two years is recommended as good practice. Bearings not provided with external accessible grease fittings do not require lubrication after leaving the factory.



# GUS™ VERTICAL AXIS WIND TURBINES INSTRUCTION AND OPERATION MANUAL

## 5.4 Service

### **WARNING!**

THERE ARE NO OWNER SERVICEABLE PARTS INSIDE THE GENERATOR. OPENING THE GENERATOR HOUSING WILL VOID THE WARRANTY AND COULD BE DANGEROUS.

### **WARNING!**

DO NOT ATTEMPT TO TROUBLESHOOT OR SERVICE THE ELECTRICAL SYSTEM THAT INCLUDES THE WIND GENERATOR WITHOUT PROPER TRAINING.

### 5.4.1 Electrical System Service

#### General

The GUS™ wind turbine is a 3-phase, permanent magnet, multi-pole generator capable of producing voltage and current levels sufficient to provide electrical hazard. Provide your qualified electrician with the appropriate electrical schematic that represents your complete installed system for the protection of all individuals.

Electrical systems are highly reliable and trouble free. The cause of an interruption in the system is most often traced to an unrelated activity such as wiring damage, rather than component failure. Usually, system problems can be traced to blown fuses damaged wiring or loose connections.

If the electrician has completed system checks and still believes there is a fault within the generator itself, then he should complete the following steps for testing the generator requiring service:

**BEFORE ANY TESTS CAN BE CONDUCTED, THE GENERATOR SHAFT MUST BE RESTRAINED TO PROHIBIT ROTATION AND THE GENERATOR LEADS SHOULD BE DISCONNECTED AT THE GENERATOR JUNCTION BOX.**

Step 1) Verify that the Serial Number identification from inside the generator junction box matches the exterior label identification.

Step 2) Complete a Winding DC Resistance Test.

Resistance for each stator winding should be measured and reported in ohms.

Step 3) Complete a Hi-Pot Test.



## GUS™ VERTICAL AXIS WIND TURBINES INSTRUCTION AND OPERATION MANUAL

Winding Insulation Resistance to ground for each stator winding should be measured and reported in megohms.

Provide this data in a written report through your equipment supplier with a request for factory service or warranty consideration.

### 5.4.2. Contact Information:

Manufacturer of Wind Turbine Generator:

GUS™ Power Inc.  
Mississauga, Ontario  
Tel: 1-800-268-7732

Name of Supplier:  
Supplier Tel.#:

Name of Installer:  
Installer Tel.#:

Installation Date:

----/----/----

Attachment A: GUS™ 1EL Drawing

# GUS™ VERTICAL AXIS WIND TURBINES INSTRUCTION AND OPERATION MANUAL

## Attachment B: Basic Turbine Battery Connection

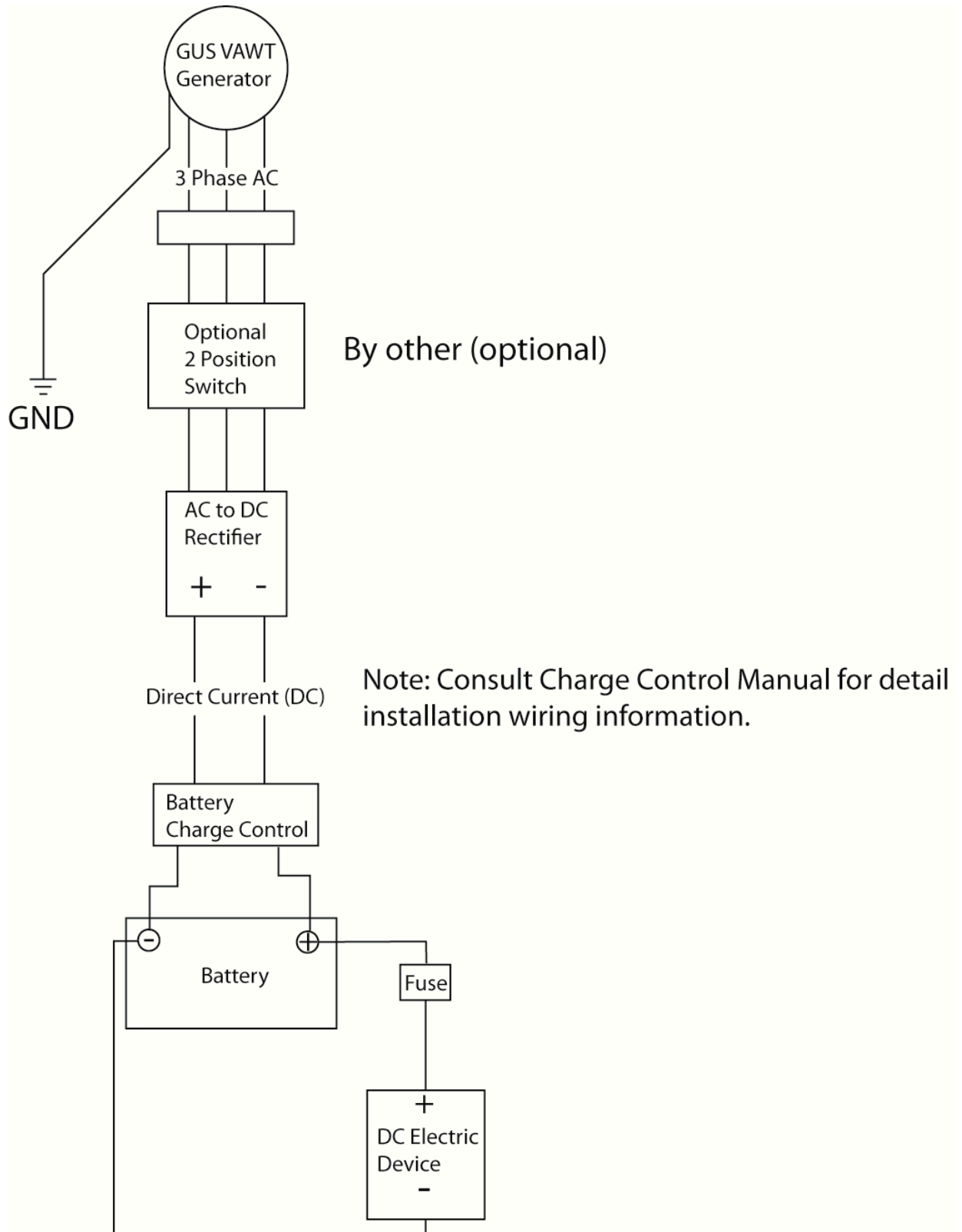

# GUS™ VERTICAL AXIS WIND TURBINES INSTRUCTION AND OPERATION MANUAL

## Attachment C: Spun Concrete Pole

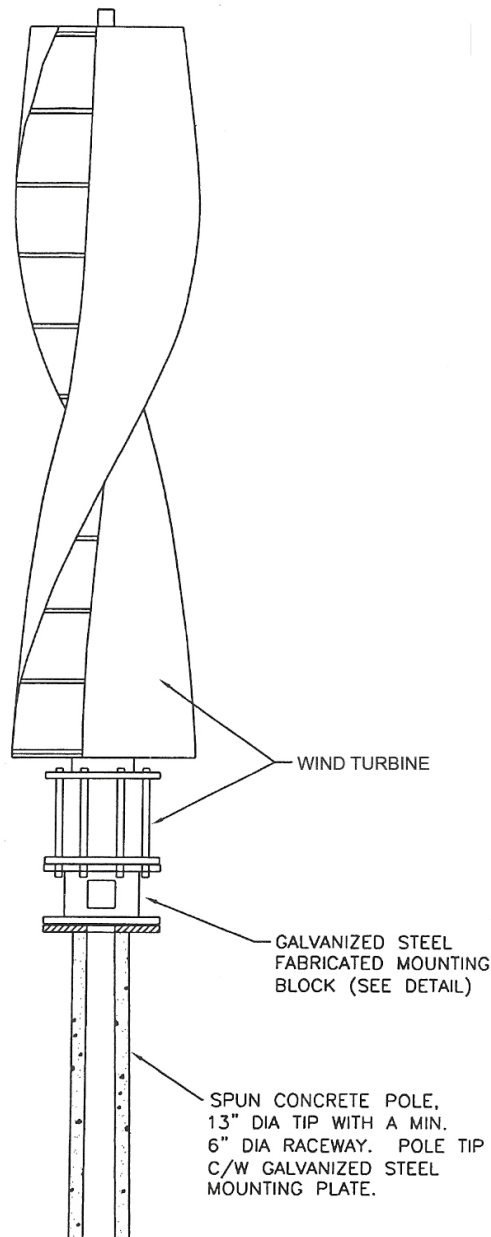

Poles shall be pre-stressed and/or reinforced concrete with dimensions, tapers and cross-sections as engineered for each application. The concrete used shall achieve a minimum 28-day compressive strength, of 8,000 psi. Poles shall be steam cured to a 3-day strength, and thereafter stored under cover for 72 hours at a minimum temperature of 50 degrees Fahrenheit (10 degrees Celsius). In areas subject to frequent freeze/thaw conditions, an air entrainment admixture shall be used to produce a 5-8% air content in the mix.



## GUS™ VERTICAL AXIS WIND TURBINES INSTRUCTION AND OPERATION MANUAL

Pre-stressing steel reinforcement shall be stressed to a maximum of 70% of their ultimate capacity, and shall not be released until a minimum compressive strength of 3,500 psi has been achieved.